

Монитор УЗО Технические характеристики



Архангельск (8182)63-90-72
Астана +7(7172)727-132
Астрахань (8512)99-46-04
Барнаул (3852)73-04-60
Белгород (4722)40-23-64
Брянск (4832)59-03-52
Владивосток (423)249-28-31
Волгоград (844)278-03-48
Вологда (8172)26-41-59
Воронеж (473)204-51-73
Екатеринбург (343)384-55-89
Иваново (4932)77-34-06
Ижевск (3412)26-03-58
Казань (843)206-01-48

Калининград (4012)72-03-81
Калуга (4842)92-23-67
Кемерово (3842)65-04-62
Киров (8332)68-02-04
Краснодар (861)203-40-90
Красноярск (391)204-63-61
Курск (4712)77-13-04
Липецк (4742)52-20-81
Магнитогорск (3519)55-03-13
Москва (495)268-04-70
Мурманск (8152)59-64-93
Набережные Челны (8552)20-53-41
Нижний Новгород (831)429-08-12
Новокузнецк (3843)20-46-81

Новосибирск (383)227-86-73
Омск (3812)21-46-40
Орел (4862)44-53-42
Оренбург (3532)37-68-04
Пенза (8412)22-31-16
Пермь (342)205-81-47
Ростов-на-Дону (863)308-18-15
Рязань (4912)46-61-64
Самара (846)206-03-16
Санкт-Петербург (812)309-46-40
Саратов (845)249-38-78
Севастополь (8692)22-31-93
Симферополь (3652)67-13-56
Смоленск (4812)29-41-54

Сочи (862)225-72-31
Ставрополь (8652)20-65-13
Сургут (3462)77-98-35
Тверь (4822)63-31-35
Томск (3822)98-41-53
Тула (4872)74-02-29
Тюмень (3452)66-21-18
Ульяновск (8422)24-23-59
Уфа (347)22948 -12
Хабаровск (4212)92-98-04
Челябинск (351)202-03-61
Череповец (8202)49-02-64
Ярославль (4852)69-52-93

Hospital Monitor (Early Bird)

The Early Bird hospital earth leakage monitor was developed to meet the requirements laid down by the South African Bureau of Standards code of practice SABS 051/1973, Part II.



EB225H

Features

- Sensitive measurement ($> 200 \text{ k}\Omega$)
- Calibrated $5 \text{ k}\Omega$ alarm level
- Automatic reset when fault is cleared
- Large dial display for early detection
- Built-in indicator lamps (red, green)
- Connector block for remote lamps, alarm connection and mute button
- Built-in test button
- Built-in mute button
- Can detect AC, rectified (DC) and balanced insulation deterioration
- Powered from the monitored supply

External Connections

- Connections to the EB 225H are by means of a multi-way connector block. Connections are:
 - 220V supply (isolated), L1 L2
 - Remote audio muting
 - Remote common
 - Remote green lamp supply*
 - Remote red lamp supply*
 - Remote audio supply*
 - Earth stud

* 120VA, each contact pair. Maximum ratings: 220V

Applications

- To protect against the hazards of electrocution and fire risk in the explosive atmospheres associated with anaesthetics, the standard practice is to install 1 : 1 ratio isolating transformers to supply all outlets in the hospital theatres.
- **WARNING:**
The Early Bird does not disconnect the supply. It provides an early warning of a fault, which should be corrected as soon as possible, as a second fault could cause large currents or electrocution.

Accessories

The following additional accessories are required to complete the Early Bird system. These are not included with the EB as supplied.

- Double wound 1 : 1 ratio double insulated transformer to suit system requirements
- Remote alarm lights
- Remote audible alarm
- Remote audible alarm mute push button (optional)

Hospital Monitor (Early Bird)

Technical Data

Principle of Operation

The Early Bird earth leakage detection device is not intended for isolating a system on which an earth fault exists, but is intended to give an indication that some part of the system developed an earth fault. The earth fault current limiting impedance which is integrally mounted in the Early Bird restricts any earth fault, even with one lead having a direct short-circuit to earth to a maximum of one milliampere.

Operation

In practice, the Early Bird is connected in the supply system as shown in the wiring diagram. The double wound isolating transformer is fundamental to this system, to obtain required isolated supply. The 220 / 250V AC power supply to Early Bird is derived from the isolated supply it is monitoring. With the system healthy, the Early Bird will register: green lamp glows – meter registering high resistance. Any deterioration of system insulation will be monitored and read out as a decrease in the k Ω reading on the meter. With the deterioration of the insulation reaching a critical level, an alarm circuit operates give visual and audible warning.

Alarm Level

The level at which alarm operation occurs is pre-set to 5000 Ω in accordance with the requirements of SANS 10142-1 § 7.7.4.5.2.

Alarm Operation

To ensure that attention is drawn to the existence of an electrical fault, a flashing red light alarm is provided. Terminals for remote repeater lamps and remote audible alarm are provided. A muting facility is provided for the audible alarm. This consists of a local push-button on the unit and terminals

for remote push-button. This facility is independent of the flashing red alarm light. All alarms, including the muting facilities, automatically reset when the insulation resistance between the isolated supply system and the earth point exceeds 5000 Ω .

Balanced Faults

Although statistically unlikely, if an equal fault occurs on both conductors of an isolated system, most presently accepted systems will be incapable of reading such a fault. The Early Bird system will respond to any combination of earth faults on the two conductors, as if both faults were connected in parallel.

Second Earth Fault

While the Early Bird provides earth fault current limiting as described above, on the first fault, it must be recognised that a second earth fault on the other conductor will be seen as a phase to phase fault, and must be cleared by the normal overload and short circuit protection systems. It is, therefore, most important that due recognition be given to the early warning afforded by this device, and steps taken to clear the first fault as soon as possible.

DC Faults

Most electronic equipment used in hospitals incorporate auxiliary DC supplies. Provided the individual auxiliary transformer feeding these DC supplies is auto-connected (i.e. a common connection provided between one side of the input winding to one side of the output winding), the Early Bird will respond to DC faults of either polarity.

Hospital Earth Leakage Monitor	
Rated Voltage (V)	220 / 250 V 50 Hz
Meter Scale	0 - 200 k Ω
Alarm Level	5000 Ω
Maximum Earth Fault Current (Single)	1 mA
Earth Impedance	> 100 k Ω
Test Voltage	< 25 V DC
Remote Alarm Mute Switch	30 V DC
Auxiliary Output Voltage	220 / 250 V
Auxiliary Output Rating (Each)	120 VA
Weight	3 kg (unpacked)

Ordering Information

Hospital Earth Leakage Monitor			
Type	Voltage	Std Pack	Order No.
EB225H (Early Bird)	220 / 250 V	1	EB99900

Hospital Monitor (Early Bird)

EB225H, Wiring Diagram

H

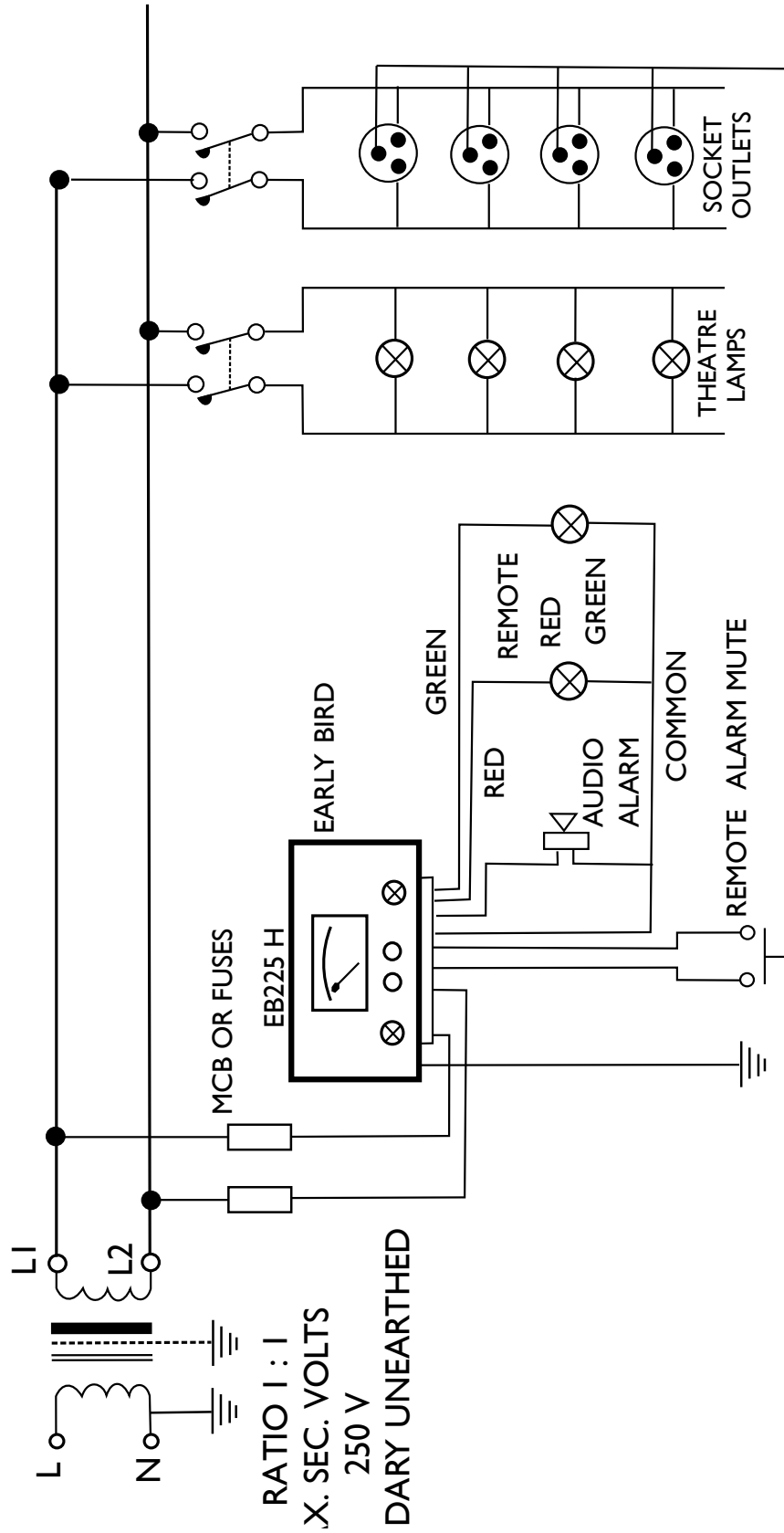

Hospital Monitor (Early Bird)

EB225H, Dimensional Drawings

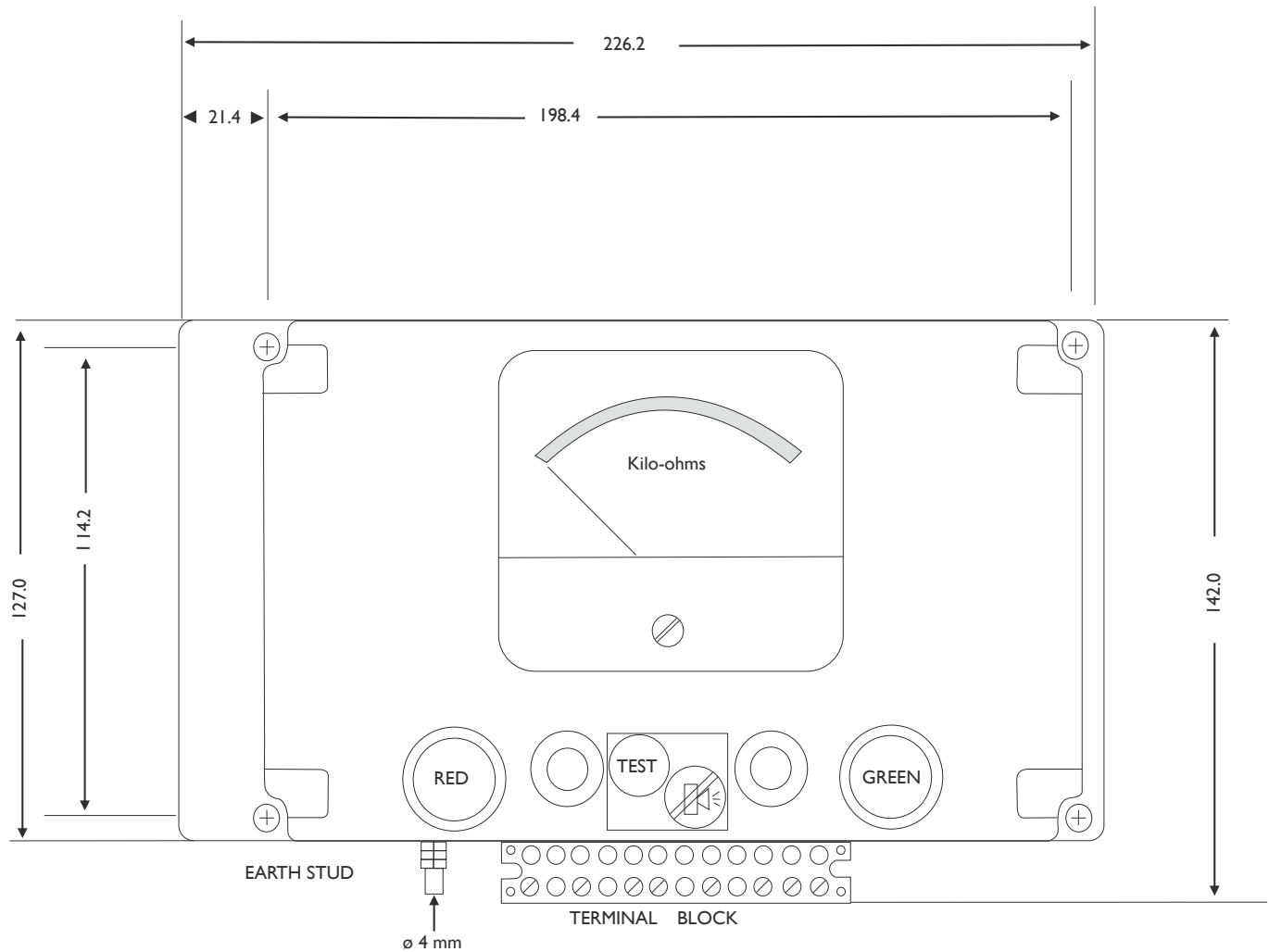

Архангельск (8182)63-90-72
 Астана +7(7172)727-132
 Астрахань (8512)99-46-04
 Барнаул (3852)73-04-60
 Белгород (4722)40-23-64
 Брянск (4832)59-03-52
 Владивосток (423)249-28-31
 Волгоград (844)278-03-48
 Вологда (8172)26-41-59
 Воронеж (473)204-51-73
 Екатеринбург (343)384-55-89
 Иваново (4932)77-34-06
 Ижевск (3412)26-03-58
 Казань (843)206-01-48

Калининград (4012)72-03-81
 Калуга (4842)92-23-67
 Кемерово (3842)65-04-62
 Киров (8332)68-02-04
 Краснодар (861)203-40-90
 Красноярск (391)204-63-61
 Курск (4712)77-13-04
 Липецк (4742)52-20-81
 Магнитогорск (3519)55-03-13
 Москва (495)268-04-70
 Мурманск (8152)59-64-93
 Набережные Челны (8552)20-53-41
 Нижний Новгород (831)429-08-12
 Новокузнецк (3843)20-46-81

Новосибирск (383)227-86-73
 Омск (3812)21-46-40
 Орел (4862)44-53-42
 Оренбург (3532)37-68-04
 Пенза (8412)22-31-16
 Пермь (342)205-81-47
 Ростов-на-Дону (863)308-18-15
 Рязань (4912)46-61-64
 Самара (846)206-03-16
 Санкт-Петербург (812)309-46-40
 Саратов (845)249-38-78
 Севастополь (8692)22-31-93
 Симферополь (3652)67-13-56
 Смоленск (4812)29-41-54

Сочи (862)225-72-31
 Ставрополь (8652)20-65-13
 Сургут (3462)77-98-35
 Тверь (4822)63-31-35
 Томск (3822)98-41-53
 Тула (4872)74-02-29
 Тюмень (3452)66-21-18
 Ульяновск (8422)24-23-59
 Уфа (347)22948 -12
 Хабаровск (4212)92-98-04
 Челябинск (351)202-03-61
 Череповец (8202)49-02-64
 Ярославль (4852)69-52-93